

sheet

data



PHOTONIC PRODUCTS

a StockerYale company



405nm Photon laser diode module + TTL modulation

Key features

- Visible light $\lambda = 405\text{nm}$
- Output power 35mW
- Elliptical output beam
- TTL Modulation up to 1kHz maximum
- Adjustable glass AR coated optics
- High reliability

Applications

- Imaging
- Spectroscopy
- Fluorescence
- Microscopy
- Biomedical instrumentation

Options

PMM: Photon Module with Modulation

PMMF: Photon Module with Modulation & Flange

Photon Laser Module + TTL Modulation : 405nm 35mW

The Photon Laser Module produces an elliptical output beam of $3.5 \times 2\text{mm}$ ($1/e^2$) with output power of 35mW at a lasing wavelength of 405nm.

Operating voltage is from 8V to 10V DC at an operating current of 80mA. Beam divergence is typically $0.6 \times 0.3\text{mrad}$.

Operating temperature range is from -10°C to $+50^\circ\text{C}$.

The 405nm Photon modules consist of an aluminium housing, laser diode, drive circuit

and collimating lens.

The PMMF modules have a 25mm mounting flange.

Electrical connections are made via external flying leads. The lens may be adjusted to produce either a collimated beam or focused spot. The standard lens may be replaced by other optical systems such as line generators.

The Photon range of laser diode modules has been designed as a complete laser diode solution for OEM use.

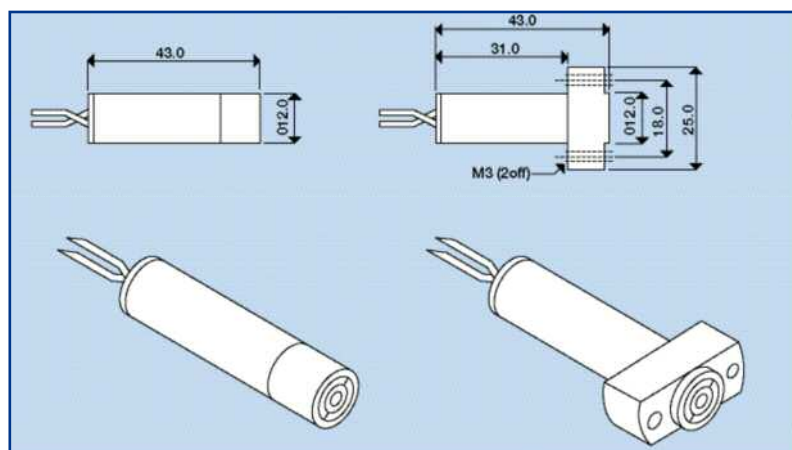

Photon laser diode module : 405nm

Specifications (typical @ tc = 25°C)

| | |
|---|-------------------------------------|
| Part no. PMM/PMMF | 708-G |
| Wavelength | 405nm |
| Output Power | 35.0mW |
| Power Stability | < 5% |
| Beam Size (1/e ²) | 3.5 x 2mm elliptical |
| Beam Divergence | <0.6 x 0.3mrad |
| Pointing Stability | <0.2mrad/°C |
| Bore Sighting | <2.0° |
| Operating Voltage (DC) | 8 - 10V DC |
| Operating Current | 80mA |
| Operating Temperature (non condensing) | -10°C to +50°C |
| Storage Temperature | -40°C to +85°C |
| Length | 43mm |
| Diameter (mounting flange 25mm) | 12mm |
| Housing Material | HE30 Anodised Aluminium |
| Flying Lead Length | 300mm |
| Modulation (All PMM / PMMF modules have DC modulation capability) | TTL OHZ-1kHz maximum, 0V=off, 5V=on |

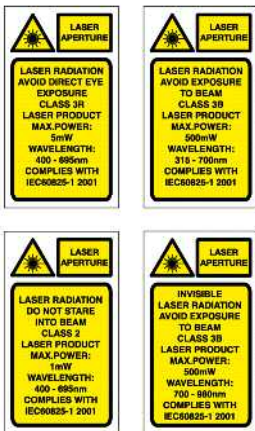

Laser Safety

The light emitted from these devices has been set in accordance with IEC60825. However, staring into the beam, whether directly or indirectly, must be avoided. IEC60825 classifies laser products into three different categories depending on light emitted, wavelength and eye safety.

CLASS II

“Caution”, visible laser light less than 1.0mW. Considered eye safe, normal exposure to this type of beam will not cause permanent damage to the retina.

CLASS IIIR

“Danger”, visible laser light between 1.0mW and 5.0mW. Considered eye safe with caution. Focusing of this light into the eye could cause some damage.

CLASS IIIB

“Danger”, infrared (IR), and high power visible lasers considered dangerous to the retina if exposed.

NB: It is important to note that while complying with the above classifications, unless otherwise stated, our laser diode products are not certified and are designed solely for use in OEM products. The way in which the device is used in the final product may alter its original design classification, and it is the responsibility of the OEM to ensure compliance with the relevant standards.

Heat Sinking

If the case temperature of the laser diode exceeds its maximum specification, premature or catastrophic failure may occur. To ensure the maximum life of the laser diode, it is recommended that an additional electrically insulated heatsink, of at least 35 sq.cm. be used. Thermal transfer cream can be used to improve contact and heat dissipation. Do not restrict air circulation around the device.

Power Connections

The Photon laser diode modules require a regulated input voltage of 8V-10V DC. Connections are made via the 2 pre-tinned external flying leads, (red is positive, black is negative). Modules with modulation have 3rd yellow wire.

WARNING: The anodised housing is internally connected to the negative supply rail. Damage to the external anodised surfaces will result in the housing being at negative potential.

Specifications subject to change without notice. E&OE



PHOTONIC PRODUCTS

a StockerYale company

PHOTONIC PRODUCTS UK LIMITED

Sparrow Lane, Hatfield Broad Oak, Hertfordshire CM22 7BA UK
tel: +44 (0) 1279 717170 e-mail: sales@photonic-products.com

PHOTONIC PRODUCTS USA

tel: +1 714-841-1960 e-mail: salesusa@photonic-products.com

PHOTONIC PRODUCTS GERMANY

tel: +49 (0) 8142 / 669 8364 e-mail: salesgermany@photonic-products.com