



sheet

Photon Plus laser diode Modules 670nm

Key features

- Visible light $\lambda = 670\text{nm}$
- Output powers from 0.9mW to 8mW
- Circulaser™ laser diode
- Adjustable optics
- High reliability

Applications

- Industrial alignment & positioning
- Bar code readers
- Medical fluorescence

Options

- PPM: Photon Plus module
- PPMF: Photon Plus module with Flange

data

670nm Circular Beam Photon Plus Laser Diode Modules

The 670nm Photon Plus Laser Modules produce a circular output beam of 1.8x1.8mm ($1/e^2$), with output powers from 0.9mW to 8mW. Operating voltage is from 2.7V to 6V DC at operating currents from 55mA to 65mA. Circularity ratio is typically 1.2:1, beam divergence is <0.6mrad and operating temperature range is -10°C to +50°C.

The inherently low beam divergence of the Circulaser™ diode, coupled with high quality coated optics results in a Gaussian beam profile, M2 values of 1.3 or lower, strehl ratios higher than 0.86 and significantly more usable optical power.

The modules consist of an aluminium housing, Circulaser™ laser diode, drive circuit and

collimating lens. They can be supplied in various colours, (red, green, blue, black, violet), to assist in wavelength or power identification.

The PPMF modules have a 25mm mounting flange.

Electrical connections are made via external flying leads. The lens may be adjusted to produce either a collimated beam or focused spot. The standard lens may be replaced by other optical systems such as line generators.

The Photon Plus range of circular beam laser diode modules has been designed as complete laser diode systems for OEM use, offering diffraction limited, non-astigmatic performance.

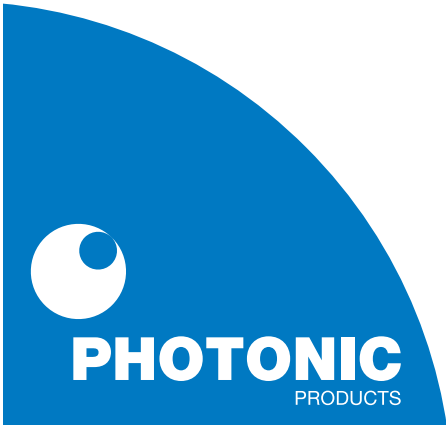
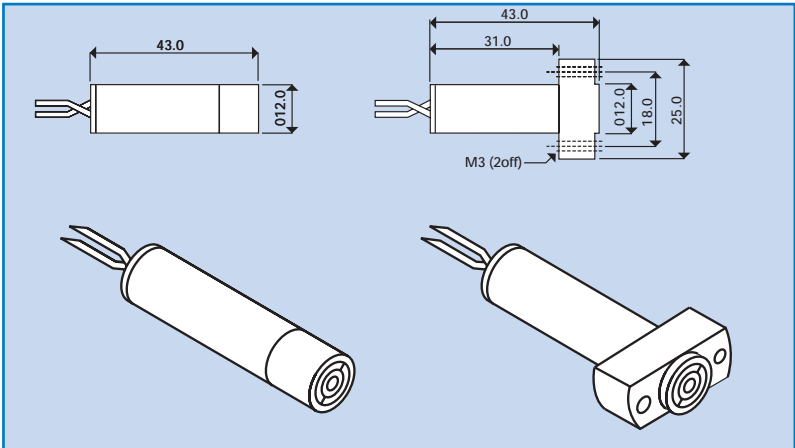

the **Laser Diode** specialists

Photon Plus laser diode Modules 670nm

Specifications (typical @ $t_c = 25^\circ\text{C}$)

| Part no. PPM/PPMF | 103-P | 203-P | 303-P |
|--|-------------------------|--|-------|
| Wavelength | 670nm | 670nm | 670nm |
| Output Power | 0.9mW | 4.0mW | 8.0mW |
| Power Stability | | < 5% | |
| Beam Size ($1/e^2$) | | 1.8x1.8mm | |
| Minimum Spot Size | | 50 μm | |
| Beam Divergence | | 0.6mrad | |
| Pointing Stability | | <0.2mrad/ $^\circ\text{C}$ | |
| Bore Sighting | | <2.0 $^\circ$ | |
| Operating Voltage (DC) | | 2.7-6.0V | |
| Operating Current | 60mA | 65mA | 55mA |
| Operating Temperature (non condensing) | | -10 $^\circ\text{C}$ to +50 $^\circ\text{C}$ | |
| Storage Temperature | | -40 $^\circ\text{C}$ to +85 $^\circ\text{C}$ | |
| Length | | 43mm | |
| Diameter (mounting flange 25mm) | | 12mm | |
| Housing Material | HE30 Anodised Aluminium | | |
| Flying Lead Length | | 300mm | |

Heat Sinking

If the case temperature of the laser diode exceeds its maximum specification, premature or catastrophic failure may occur. To ensure the maximum life of the laser diode, it is recommended that an additional electrically insulated heatsink, of at least 35 sq.cm. be used. Thermal transfer cream can be used to improve contact and heat dissipation. Do not restrict air circulation around the device.

Power Connections

The Photon Plus laser diode modules require a regulated input voltage of 2.7-6V DC. Connections are made via the 2 pre-tinned external flying leads, (red is positive, black is negative).

WARNING: The anodised housing is internally connected to the positive supply rail. Damage to the external anodised surfaces will result in the housing being at positive potential.

Specifications subject to change without notice. E&OE

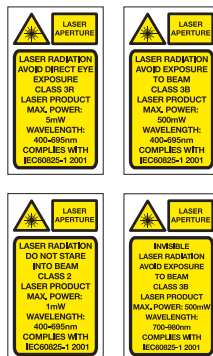

Laser Safety

The light emitted from these devices has been set in accordance with IEC60825. However, staring into the beam, whether directly or indirectly, must be avoided. IEC60825 classifies laser products into three different categories depending on light emitted, wavelength and eye safety.

CLASS II

"Caution", visible laser light less than 1.0mW. Considered eye safe, normal exposure to this type of beam will not cause permanent damage to the retina.

CLASS III R

"Danger", visible laser light between 1.0mW and 5.0mW. Considered eye safe with caution. Focusing of this light into the eye could cause some damage.

CLASS III B

"Danger", infrared (IR), and high power visible lasers considered dangerous to the retina if exposed.

NB: It is important to note that while complying with the above classifications, unless otherwise stated, our laser diode products are not certified and are designed solely for use in OEM products. The way in which the device is used in the final product may alter its original design classification, and it is the responsibility of the OEM to ensure compliance with the relevant standards.

PHOTONIC PRODUCTS UK LIMITED

Pierce Williams, Sparrow Lane
Hatfield Broad Oak, Hertfordshire CM22 7BA UK
Telephone: +44 (0) 1279 717170
Facsimile: +44 (0) 1279 717171
E-mail: sales@photonic-products.com
www.photonic-products.com

PHOTONIC PRODUCTS USA

Telephone: +1 714-841-1960
E-mail: salesusa@photonic-products.com

PHOTONIC PRODUCTS GERMANY

Telefon: +49 (0) 8142 / 669 8364
E-mail: salesgermany@photonic-products.com
www.photonic-products.com



PHOTONIC
PRODUCTS

Issue C:10/04

the **Laser Diode** specialists