



**PHOTONIC
PRODUCTS**

a StockerYale company



635nm compact laser diode module

Key features

- Visible light $\lambda = 635\text{nm}$
- Output powers 0.9mW, 4.0mW
- 8mm diameter, 25.5mm length
- Hard anodised housing
- High reliability

Applications

- Industrial alignment
- Patient positioning

635nm Compact Laser Diode Modules

The 635nm Compact Laser Diode Modules produce an elliptical, collimated output beam of $3.5 \times 1.5\text{mm}$ ($1/e^2$), with output powers of 0.9mW or 4.0mW. Operating voltage is from 3V to 6V DC at an operating current of 30mA typ (0.9mW) or 40mA typ.(4.5mW).

Beam divergence is $<1\text{mrad}$ and operating temperature range is -10°C to $+40^\circ\text{C}$.

The modules consist of a hard anodised aluminium housing (for electrical isolation),

laser diode, drive circuit and adjustable collimating/focusing lens.

Electrical connections are made via external flying leads. The lens may be adjusted to produce either a collimated beam or focused spot.

The Compact range of elliptical beam laser diode modules has been designed as complete laser diode solutions for OEM use.

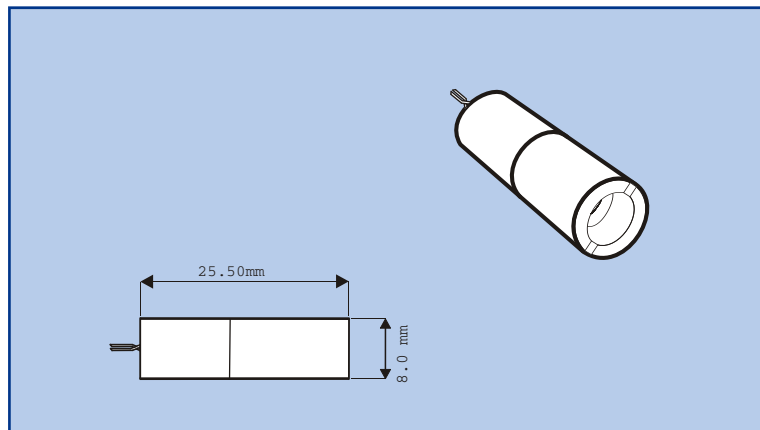

compact laser diode module 635nm

Specifications (typical @ tc = 25°C)

Part no.	300-0222-00	300-0223-00
Wavelength	635nm typ., 640nm max	635nm typ., 640nm max
Output Power	0.9mW ±5% @ 25°C	4mW ±5% @ 25°C
Power Stability	< 5%	< 5%
Collimated Beam Size (1/e ²)	3.5x1.5mm typ.	3.5x1.5mm typ.
Collimated Beam Divergence	< 1 mrad	< 1 mrad
Operating Voltage (DC)	3.0-6.0V	3.0-6.0V
CW Operating Current	30mA typ., 45mA max	40mA typ., 50mA max
Operating Temperature (non-condensing)	-10°C to +40°C	-10°C to +40°C
Storage Temperature	-40°C to +85°C	-40°C to +85°C
Length	25.5mm	25.5mm
Diameter	8mm	8mm
Housing Material	Aluminium - Hard Anodised	
Flying Lead Length	300mm	300mm
Circuit Protection	Static, Surge and Reverse Polarity Protected	

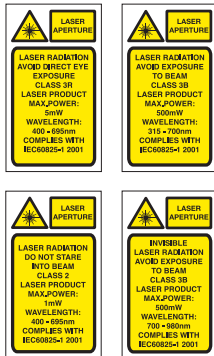

Laser Safety

The light emitted from these devices has been set in accordance with IEC60825. However, staring into the beam, whether directly or indirectly, must be avoided. IEC60825 classifies laser products into three different categories depending on light emitted, wavelength and eye safety.

CLASS II

"Caution", visible laser light less than 1.0mW. Considered eye safe, normal exposure to this type of beam will not cause permanent damage to the retina.

CLASS IIIIR

"Danger", visible laser light between 1.0mW and 5.0mW. Considered eye safe with caution. Focusing of this light into the eye could cause some damage.

CLASS IIIIB

"Danger", infrared (IR), and high power visible lasers considered dangerous to the retina if exposed.

NB: It is important to note that while complying with the above classifications, unless otherwise stated, our laser diode products are not certified and are designed solely for use in OEM products. The way in which the device is used in the final product may alter its original design classification, and it is the responsibility of the OEM to ensure compliance with the relevant standards.

Heat Sinking

If the case temperature of the laser diode exceeds its maximum specification, premature or catastrophic failure may occur. To ensure the maximum life of the laser diode, it is recommended that an additional electrically insulated heatsink, of at least 35 sq.cm. be used. Thermal transfer cream can be used to improve contact and heat dissipation. Do not restrict air circulation around the device.

Power Connections

The compact laser diode modules require a regulated input voltage of 3V-6V DC. Connections are made via the 2 pre-tinned external flying leads, (red is positive, black is negative). Modules with modulation have 3rd yellow wire.

WARNING: The anodised housing is internally connected to the positive supply rail. Damage to the external anodised surfaces will result in the housing being at negative potential.

Specifications subject to change without notice. E&OE



**PHOTONIC
PRODUCTS**
a StockerYale company

PHOTONIC PRODUCTS UK LIMITED

Sparrow Lane, Hatfield Broad Oak, Hertfordshire CM22 7BA UK

Telephone: +44 (0) 1279 717170 E-mail: sales@photonic-products.com

PHOTONIC PRODUCTS USA

Telephone: +1 714-841-1960 E-mail: salesusa@photonic-products.com

PHOTONIC PRODUCTS GERMANY

Telefon: +49 (0) 8142 / 669 8364 E-mail: salesgermany@photonic-products.com