

sheet

data

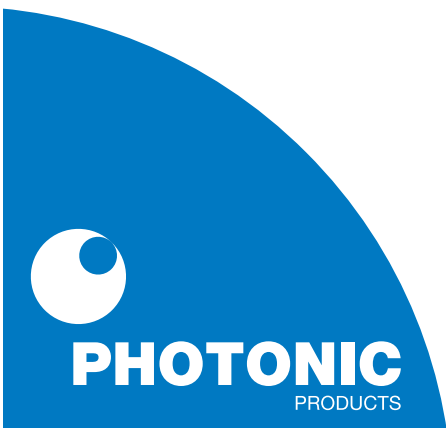

Photon laser diode Modules 660nm 70mW

Key features

- Visible light $\lambda = 660\text{nm}$
- Output power 70mW
- AR coated glass optics
- Adjustable optics
- High reliability

Applications

- Industrial alignment & positioning
- Machine vision
- Inspection systems
- Medical imaging
- Graphic displays

Options

- PM: Photon Module
- PMF: Photon Module with Flange

660nm Elliptical Beam Photon Laser Diode Module

The 660nm Photon Laser Module produces an elliptical output beam of 3.5 x 1.5mm ($1/e^2$), with an output power of 70mW. Operating voltage is from 3V to 6V DC with a typical operating current of 150mA. Beam divergence is $<0.6 \times 0.3\text{mrad}$ and operating temperature range is -10°C to $+50^\circ\text{C}$.

The module consists of an aluminium housing, Opnext HL6548FG laser diode, drive circuit and collimating lens. All Photon Modules can be supplied in various colours, (red, green, blue, black, violet), to assist in

wavelength or power identification.

The PMF modules have a 25mm mounting flange.

Electrical connections are made via external flying leads. The lens may be adjusted to produce either a collimated beam or focused spot. The standard lens may be replaced by other optical systems such as line generators.

The Photon range of elliptical beam laser diode modules has been designed as complete laser diode systems for OEM use.

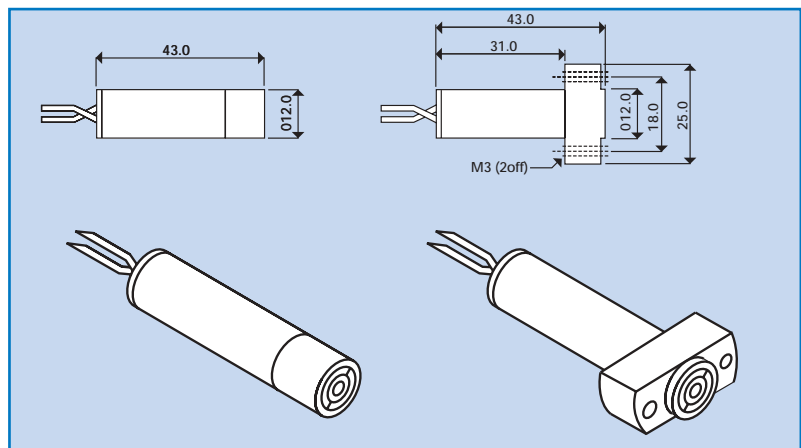

the **Laser Diode** specialists

Photon laser diode Modules 660nm 70mW

Specifications (typical @ tc = 25°C)

Part no. PM/PMF	806G-GR
Wavelength	660nm
Output Power	70mW
Power Stability	< 5%
Beam Size (1/e ²)	3.5x1.5mm
Beam Divergence	0.6x0.3mrad
Pointing Stability	<0.2mrad/°C
Bore Sighting	<2.0°
Operating Voltage (DC)	3.0-6.0V
Operating Current	150mA
Operating Temperature (non-condensing)	-10°C to +50°C
Storage Temperature	-40°C to +85°C
Length	43mm
Diameter (mounting flange 25mm)	12mm
Housing Material	HE30 Anodised Aluminium
Flying Lead Length	300mm

Heat Sinking

If the case temperature of the laser diode exceeds its maximum specification, premature or catastrophic failure may occur. To ensure the maximum life of the laser diode, it is recommended that an additional electrically insulated heatsink, of at least 35 sq.cm. be used. Thermal transfer cream can be used to improve contact and heat dissipation. Do not restrict air circulation around the device.

Power Connections

The Photon laser diode modules require a regulated input voltage of 3.0-6.0V DC. Connections are made via the 2 pre-tinned external flying leads, (red is positive, black is negative).

WARNING: The anodised housing is internally connected to the positive supply rail. Damage to the external anodised surfaces will result in the housing being at positive potential.

Specifications subject to change without notice. E&OE

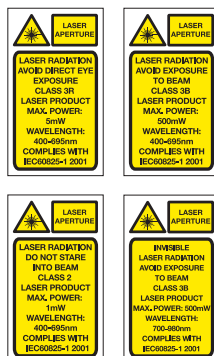

Laser Safety

The light emitted from these devices has been set in accordance with IEC60825. However, staring into the beam, whether directly or indirectly, must be avoided. IEC60825 classifies laser products into three different categories depending on light emitted, wavelength and eye safety.

CLASS II

"Caution", visible laser light less than 1.0mW. Considered eye safe, normal exposure to this type of beam will not cause permanent damage to the retina.

CLASS IIIR

"Danger", visible laser light between 1.0mW and 5.0mW. Considered eye safe with caution. Focusing of this light into the eye could cause some damage.

CLASS IIIB

"Danger", infrared (IR), and high power visible lasers considered dangerous to the retina if exposed.

NB: It is important to note that while complying with the above classifications, unless otherwise stated, our laser diode products are not certified and are designed solely for use in OEM products. The way in which the device is used in the final product may alter its original design classification, and it is the responsibility of the OEM to ensure compliance with the relevant standards.

PHOTONIC PRODUCTS UK LIMITED

Pierce Williams, Sparrow Lane
Hatfield Broad Oak, Hertfordshire CM22 7BA UK
Telephone: +44 (0) 1279 717170
Facsimile: +44 (0) 1279 717171
E-mail: sales@photonic-products.com
www.photonic-products.com

PHOTONIC PRODUCTS USA

Telephone: +1 714-841-1960
E-mail: salesusa@photonic-products.com

PHOTONIC PRODUCTS GERMANY

Telefon: +49 (0) 8142 / 669 8364
E-mail: salesgermany@photonic-products.com
www.photonic-products.com



PHOTONIC
PRODUCTS