

sheet

data



**PHOTONIC  
PRODUCTS**  
a StockerYale company



## Photon laser diode modules : 850nm

### Key features

- Infra-red light  $\lambda = 850\text{nm}$
- Output power 25mW
- Adjustable optics
- Compact and self-contained
- High reliability

### Applications

- Machine vision
- Spectroscopy
- Industrial inspection
- Sensors

### Options

PM: Photon Module

PMF: Photon Module with Flange

## Photon Laser Diode Module : 850nm

The Photon Laser Modules produce an elliptical output beam of  $4.0 \times 2.0\text{mm}$  ( $1/e^2$ ), with an output power of 25mW at a lasing wavelength of 850nm. Operating voltage is from 2.7V to 6V DC at an operating current of 120mA.

Beam divergence is  $<0.6 \times 0.5\text{mrad}$  and operating temperature range is  $-10^\circ\text{C}$  to  $+50^\circ\text{C}$ .

The module consists of an aluminium housing, laser diode, drive circuit and collimating lens.

The Photon module can be supplied in various colours, (red, green, blue, black, violet), to assist

in wavelength or power identification.

The Photon PMF modules have a 25mm mounting flange.

Electrical connections are made via external flying leads. The lens may be adjusted to produce either a collimated beam or focused spot. The standard lens may be replaced by other optical systems such as line generators.

The Photon range of laser diode modules has been designed as a complete laser diode solution for OEM use.

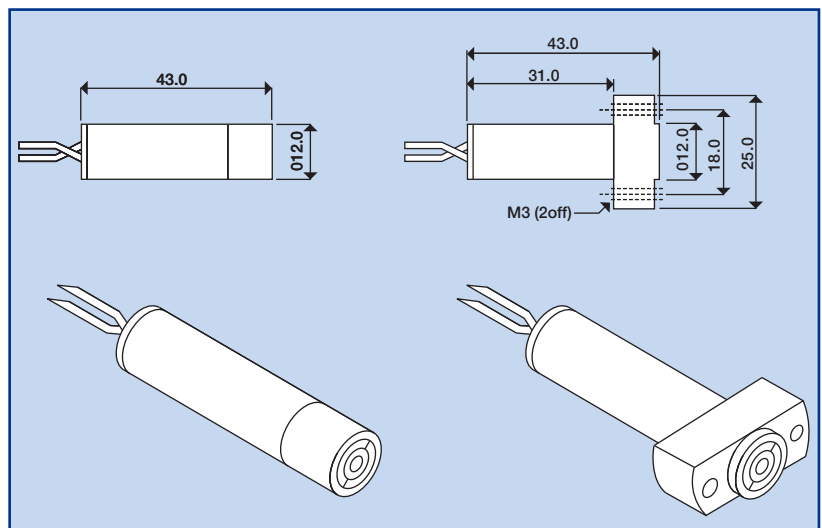

## Photon laser diode modules : 850nm

### Specifications (typical @ tc = 25°C)

Part Number PM/PMF	<b>609-P</b>
Wavelength	850nm
Output Power	25.0mW
Power Stability	< 5%
Beam Size (typ 1/e <sup>2</sup> )	4.0 x 2.0mm
Beam Divergence (full angle)	0.6 x 0.5mrad
Pointing Stability	<0.2mrad/°C
Bore Sighting	<2.0°
Operating Voltage	2.7-6.0V DC
Operating Current (25°C)	120mA
Operating Temperature (non-condensing)	-10°C to +50°C
Storage Temperature	-40°C to +80°C
Housing Material	HE30 Anodised Aluminium
Mechanical (mounting flange 25mm)	12mm ± 0.1mm diameter, 43mm length
Flying Lead Length	300mm

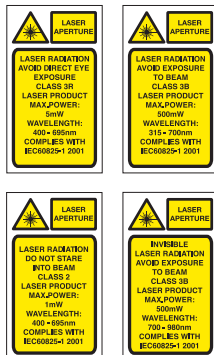

### Laser Safety

The light emitted from these devices has been set in accordance with IEC60825. However, staring into the beam, whether directly or indirectly, must be avoided. IEC60825 classifies laser products into three different categories depending on light emitted, wavelength and eye safety.

#### CLASS II

"Caution", visible laser light less than 1.0mW. Considered eye safe, normal exposure to this type of beam will not cause permanent damage to the retina.

#### CLASS IIIR

"Danger", visible laser light between 1.0mW and 5.0mW. Considered eye safe with caution. Focusing of this light into the eye could cause some damage.

#### CLASS IIIB

"Danger", infrared (IR), and high power visible lasers considered dangerous to the retina if exposed.

NB: It is important to note that while complying with the above classifications, unless otherwise stated, our laser diode products are not certified and are designed solely for use in OEM products. The way in which the device is used in the final product may alter its original design classification, and it is the responsibility of the OEM to ensure compliance with the relevant standards.

### Heat Sinking

If the case temperature of the laser diode exceeds its maximum specification, premature or catastrophic failure may occur. To ensure the maximum life of the laser diode, it is recommended that an additional electrically insulated heatsink, of at least 35 sq.cm. be used. Thermal transfer cream can be used to improve contact and heat dissipation. Do not restrict air circulation around the device.

### Power Connections

The Photon laser diode modules require a regulated input voltage of 2.7-6V DC. Connections are made via the 2 pre-tinned external flying leads, (red is positive, black is negative).

**WARNING:** The anodised housing is internally connected to the positive supply rail. Damage to the external anodised surfaces will result in the housing being at positive potential.

Specifications subject to change without notice. E&OE



**PHOTONIC  
PRODUCTS**  
a StockerYale company

#### PHOTONIC PRODUCTS UK LIMITED

Sparrow Lane, Hatfield Broad Oak, Hertfordshire CM22 7BA UK  
Tel: +44 (0) 1279 717170 E-mail: [sales@photonic-products.com](mailto:sales@photonic-products.com)

#### PHOTONIC PRODUCTS USA

Tel: +1 714-841-1960 E-mail: [salesusa@photonic-products.com](mailto:salesusa@photonic-products.com)

#### PHOTONIC PRODUCTS GERMANY

Tel: +49 (0) 8142 / 669 8364 E-mail: [salesgermany@photonic-products.com](mailto:salesgermany@photonic-products.com)