

# 830nm TE Cooled laser diode module

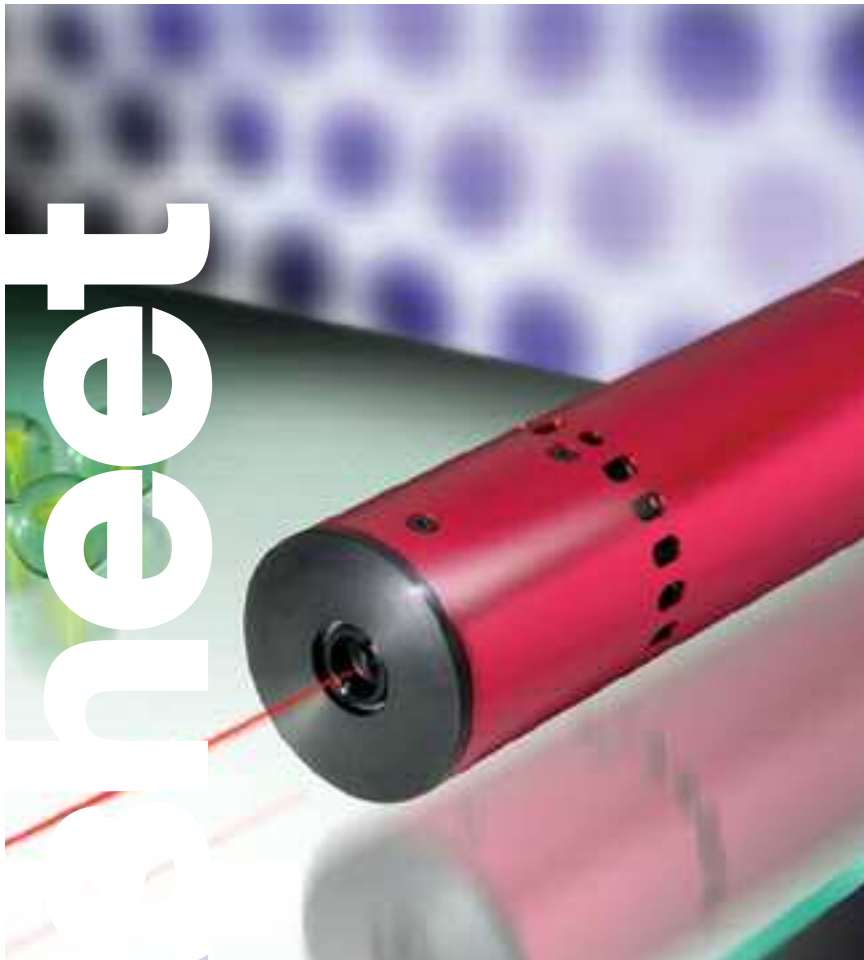

## Key features

- Visible light  $\lambda = 830\text{nm}$
- Elliptical beam
- Exceptional wavelength & power stability
- Active temperature control
- Increased laser diode lifetime
- User adjustable optics

## Applications

- Machine vision
- Spectroscopy & microscopy
- Industrial inspection
- Medical instrumentation

## 830nm Thermo-Electrically Cooled Laser Diode Modules

The 300-0690-00 series of thermo-electrically cooled, (TEC), laser diode modules produce an elliptical output beam in the invisible 830nm wavelength band and output powers from 20mW to 100mW.

The TEC laser diode module incorporates microprocessor based temperature control electronics, thermo electric cooler, heatsink and fan that enable the laser diode temperature to be controlled to a set point temperature between +18°C to +25°C, (user adjustable), and with a stability of  $\pm 0.05^\circ\text{C}$ . This accurate temperature control, together with user

adjustment of the laser diode drive current, enables the laser to be tuned to a region where mode hopping and RMS noise are significantly reduced or eliminated. Accurate temperature control also produces excellent wavelength and power stability and cooling the laser diode to 18°C significantly increases laser diode lifetime.

All infrared, red, blue, violet and UV TEC laser diode modules in the range offer low and high temperature automatic shut-off protection, analogue and digital modulation capability and safety interlock as standard.

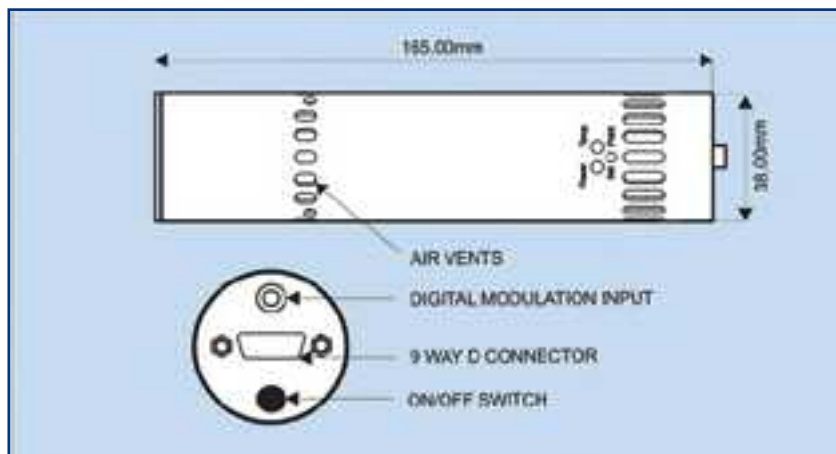

**PHOTONIC PRODUCTS**

a StockerYale company

# 830nm TE Cooled laser diode module

## Specifications

ITEM / PART no.	300-0690-00	300-0692-00
Wavelength	830nm ±10nm	830nm ±10nm
Output Power <sup>1</sup>	20.0mW	100.0mW
Power Stability	<1%	<1%
Beam Size <sup>2</sup>	6 x 2.2 mm	6 x 2.2 mm
Beam Divergence	0.2 x 0.4 mrad	0.2 x 0.4 mrad
RMS Noise	<1%	<1%
Operating Voltage	+5V ± 0.1V DC	+5V ± 0.1V DC
Operating Current	2.5A maximum (laser diode 500mA maximum)	
Ambient Temp. Range	+10°C to +30°C (non-condensing)	+10°C to +30°C (non-condensing)
Temperature Stability	± 0.05°C	± 0.05°C
Setpoint Temp. Range <sup>3</sup>	+18°C to +25°C	+18°C to +25°C
Analogue Modulation	0Hz to 10kHz, low=100% high=approx 0%	
Digital Modulation (TTL input)	ON/OFF DC to > 5MHz	
Mechanical	38mm ± 0.1mm diameter, 165mm length	

### NOTES

1. Output power is user adjustable from maximum figure indicated above down to 0mW. Adjustment is made via trim pot accessed through module housing.
2. Output beam is user adjustable, but is factory set for collimation. Adjustment is made using tool provided.
3. Setpoint temperature is user adjustable and laser diode temperature can be set anywhere in the range +18°C to +25°C. Setpoint temperature is factory set to 18°C.

Specifications subject to change without notice. E&OE.

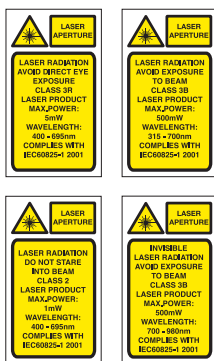

## Laser Safety

The light emitted from these devices has been set in accordance with IEC60825. However, staring into the beam, whether directly or indirectly, must be avoided. IEC60825 classifies laser products into three different categories depending on light emitted, wavelength and eye safety.

### CLASS II

"Caution", visible laser light less than 1.0mW. Considered eye safe, normal exposure to this type of beam will not cause permanent damage to the retina.

### CLASS IIIIR

"Danger", visible laser light between 1.0mW and 5.0mW. Considered eye safe with caution. Focusing of this light into the eye could cause some damage.

### CLASS IIIB

"Danger", infrared (IR), and high power visible lasers considered dangerous to the retina if exposed.

NB: It is important to note that while complying with the above classifications, unless otherwise stated, our laser diode products are not certified and are designed solely for use in OEM products. The way in which the device is used in the final product may alter its original design classification, and it is the responsibility of the OEM to ensure compliance with the relevant standards.



**PHOTONIC  
PRODUCTS**  
a StockerYale company

#### PHOTONIC PRODUCTS UK LIMITED

Sparrow Lane, Hatfield Broad Oak, Hertfordshire CM22 7BA UK

Telephone: +44 (0) 1279 717170 E-mail: [sales@photonic-products.com](mailto:sales@photonic-products.com)

#### PHOTONIC PRODUCTS USA

Telephone: +1 714-841-1960 E-mail: [salesusa@photonic-products.com](mailto:salesusa@photonic-products.com)

#### PHOTONIC PRODUCTS GERMANY

Telefon: +49 (0) 8142 / 669 8364 E-mail: [salesgermany@photonic-products.com](mailto:salesgermany@photonic-products.com)

[www.photonic-products.com](http://www.photonic-products.com)

laser diode solutions