

sheet

data

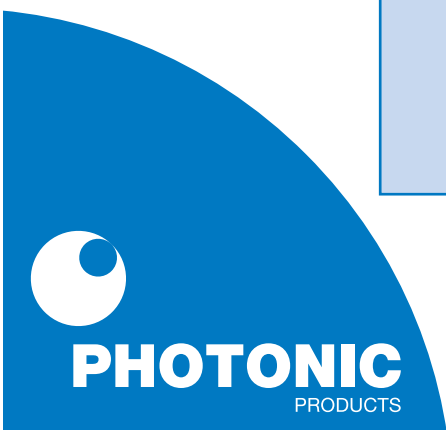

Pigtailed laser diode module 670nm

Key features

- Visible light $\lambda = 670\text{nm}$
- Fibre output power 1.2mW
- Coaxial pigtail
- FC-PC connector
- Built-in InGaAs monitor photodiode
- Laser diode with multi-quantum well structure
- Hermetically sealed active component
- High reliability

Applications

- Fibre optic test equipment
- Scientific equipment

300-0053-03 670nm Pigtailed Laser Diode Module

The 300-0053-03 670nm Pigtailed Laser Diode Module comprises a visible wavelength laser diode packaged in a

coaxial housing and FC-PC connector. It provides 1.2mW (max), fibre output power when coupled to a 9/125 μm fibre.

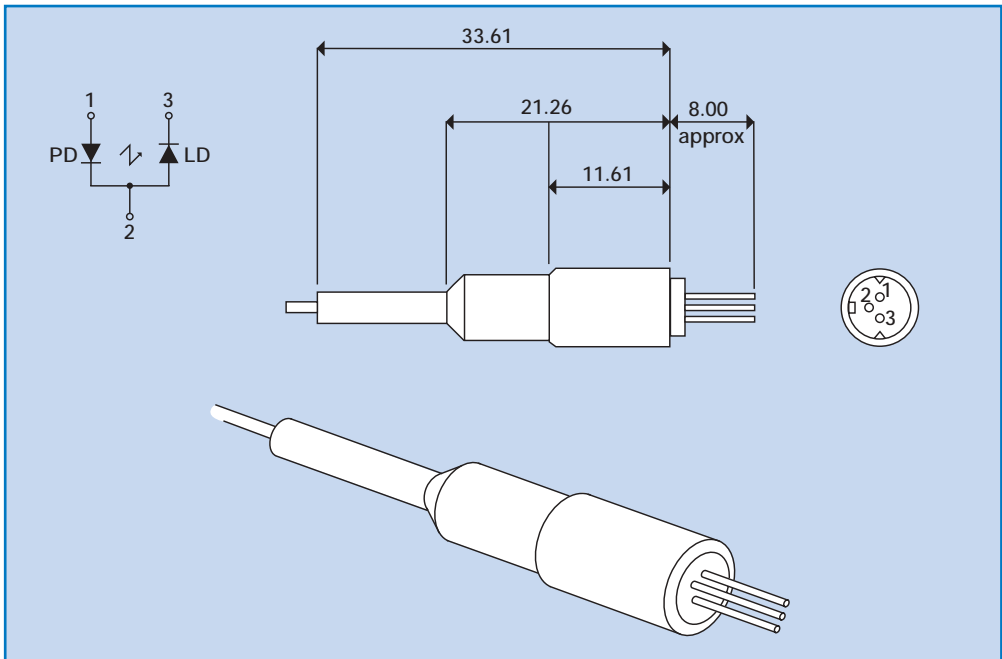

the **Laser Diode** specialists

Pigtailed laser diode module 670nm

300-0053-03 Specifications

Absolute Maximum Ratings (T_c = 25°C)

ITEM	SYMBOL	VALUE	UNIT
Fibre Output Power	P _f	1.2	mW
LD Reverse Voltage	V _{RLD}	2	V
PD Reverse Voltage	V _{RPD}	30	V
Operating Temperature	T _{opr}	-10, +60	°C
Storage Temperature	T _{stg}	-40, +85	°C

Optical & Electrical Characteristics All optical data refer to a coupled 9/125µm fibre, (T_c = 25°C).

ITEM	SYMBOL	MIN.	TYP.	MAX.	UNIT	TESTING CONDITION
Fibre Output Power	P _f	0.7	1.0	1.2	mW	
Threshold Current	I _{th}	-	25	35	mA	CW
Peak Wavelength	λ	660	670	678	nm	P _f =1.0mW
Operating Current	I _{op}	-	40	45	mA	P _f =1.0mW
Operating Voltage	V _{op}	-	2.3	2.6	V	P _f =1.0mW
PD Monitor Current	I _m	0.5	1.5	2.0	mA	P _f =1.0mW

WARNING:

This laser device in operation produces visible and/or invisible laser radiation. Be sure to avoid direct exposure of human eyes to beams emitted from the laser diodes. Even though they are barely visible and/or invisible to the human eye, they can be extremely harmful. In particular, avoid looking directly into a laser diode or collimated beam along its optical axis when it is in operation. These devices are components to be used in producing a complete laser system. They do not emit radiation unless combined with other components by the end user.

NOTE: ESD precautions must be taken when handling this product.

Specifications subject to change without notice. E&OE

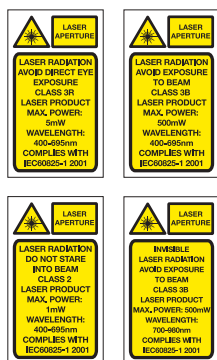

Laser Safety

The light emitted from these devices has been set in accordance with IEC60825. However, staring into the beam, whether directly or indirectly, must be avoided. IEC60825 classifies laser products into three different categories depending on light emitted, wavelength and eye safety.

CLASS II

"Caution", visible laser light less than 1.0mW. Considered eye safe, normal exposure to this type of beam will not cause permanent damage to the retina.

CLASS IIIR

"Danger", visible laser light between 1.0mW and 5.0mW. Considered eye safe with caution. Focusing of this light into the eye could cause some damage.

CLASS IIIB

"Danger", infrared (IR), and high power visible lasers considered dangerous to the retina if exposed.

NB: It is important to note that while complying with the above classifications, unless otherwise stated, our laser diode products are not certified and are designed solely for use in OEM products. The way in which the device is used in the final product may alter its original design classification, and it is the responsibility of the OEM to ensure compliance with the relevant standards.

PHOTONIC PRODUCTS UK LIMITED

Pierce Williams, Sparrow Lane
 Hatfield Broad Oak, Hertfordshire CM22 7BA, UK
 Telephone: +44 (0) 1279 717170
 Facsimile: +44 (0) 1279 717171
 E-mail: sales@photonic-products.com
www.photonic-products.com

PHOTONIC PRODUCTS USA

Telephone: +1 714-841-1960
 E-mail: salesusa@photonic-products.com

PHOTONIC PRODUCTS GERMANY

Telefon: +49 (0) 8142 / 669 8364
 E-mail: salesgermany@photonic-products.com
www.photonic-products.com



PHOTONIC
 PRODUCTS

Issue B:09/04

the **Laser Diode** specialists