



PHOTONIC PRODUCTS

a StockerYale company



785nm receptacle packaged laser diode, FC-PC connector

Key features

- Infrared light $\lambda = 785\text{nm}$
- Fibre output power 0.9mW
- FC-PC receptacle package
- Built-in AlGaInp monitor photodiode
- Laser diode with multi-quantum well structure
- Hermetically sealed active component
- High reliability

Applications

- Scientific equipment

785nm receptacle packaged laser diode, FC-PC connector

The 300-0077-00 785nm receptacle packaged laser diode with FC-PC connector provides 0.9mW (max), fibre

output power when coupled to a 9/125 μm singlemode fibre.

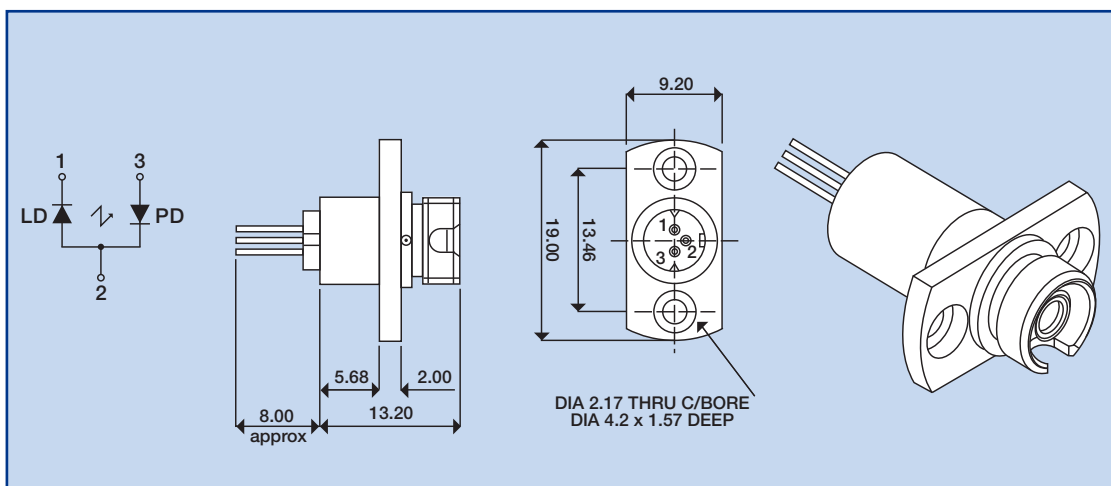

300-0077-00 Specifications

Absolute Maximum Ratings (Tc = 25°C)

ITEM	SYMBOL	VALUE	UNIT
Fibre Output Power	P _f	0.9	mW
LD Reverse Voltage	V _{RLD}	2	V
PD Reverse Voltage	V _{RPD}	30	V
Operating Temperature	T _{opr}	-10, +60	°C
Storage Temperature	T _{stg}	-40, +85	°C

Optical & Electrical Characteristics All optical data refer to a coupled 9/125µm fibre, (Tc = 25°C).

ITEM	SYMBOL	MIN.	TYP.	MAX.	UNIT	TESTING CONDITION
Fibre Output Power	P _f	0.6	0.7	0.9	mW	
Threshold Current	I _{th}	-	25	40	mA	CW
Peak Wavelength	λ	770	785	800	nm	P _f =0.7mW
Operating Current	I _{op}	-	40	55	mA	P _f =0.7mW
Operating Voltage	V _{op}	-	1.9	2.3	V	P _f =0.7mW
PD Monitor Current	I _m	1.0	2.0	3.5	mA	P _f =0.7mW

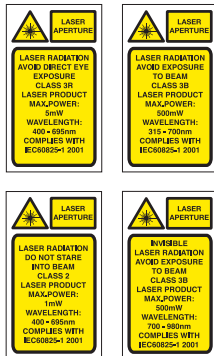

Laser Safety

The light emitted from these devices has been set in accordance with IEC60825. However, staring into the beam, whether directly or indirectly, must be avoided. IEC60825 classifies laser products into three different categories depending on light emitted, wavelength and eye safety.

CLASS II

“Caution”, visible laser light less than 1.0mW. Considered eye safe, normal exposure to this type of beam will not cause permanent damage to the retina.

CLASS IIIR

“Danger”, visible laser light between 1.0mW and 5.0mW. Considered eye safe with caution. Focusing of this light into the eye could cause some damage.

CLASS IIIB

“Danger”, infrared (IR), and high power visible lasers considered dangerous to the retina if exposed.

NB: It is important to note that while complying with the above classifications, unless otherwise stated, our laser diode products are not certified and are designed solely for use in OEM products. The way in which the device is used in the final product may alter its original design classification, and it is the responsibility of the OEM to ensure compliance with the relevant standards.

WARNING:

This laser device in operation produces visible and/or invisible laser radiation. Be sure to avoid direct exposure of human eyes to beams emitted from the laser diodes. Even though they are barely visible and/or invisible to the human eye, they can be extremely harmful. In particular, avoid looking directly into a laser diode or collimated beam along its optical axis when it is in operation. These devices are components to be used in producing a complete laser system. They do not emit radiation unless combined with other components by the end user.

NOTE: ESD precautions must be taken when handling this product.

Specifications subject to change without notice. E&OE



**PHOTONIC
PRODUCTS**
a StockerYale company

PHOTONIC PRODUCTS UK LIMITED

Sparrow Lane, Hatfield Broad Oak, Hertfordshire CM22 7BA UK

Telephone: +44 (0) 1279 717170 E-mail: sales@photonic-products.com

PHOTONIC PRODUCTS USA

Telephone: +1 714-841-1960 E-mail: salesusa@photonic-products.com

PHOTONIC PRODUCTS GERMANY

Telefon: +49 (0) 8142 / 669 8364 E-mail: salesgermany@photonic-products.com