

Receptacle packaged laser diode ST



Key features

- Wavelength = 1550nm
- Fibre output power 0.8mW
- ST receptacle package
- Built-in InGaAs monitor photodiode
- Laser diode with multi-quantum well structure
- Hermetically sealed active component
- High reliability

Applications

- Fibre optic network test equipment
- Test equipment

300-0052-02 1550nm ST Receptacle Packaged Laser Diode

The 300-0052-02 1550nm ST Receptacle Packaged Laser Diode is a telecomms wavelength laser diode.

It provides 0.8mW (max) fibre output power when coupled to a 9/125µm fibre.

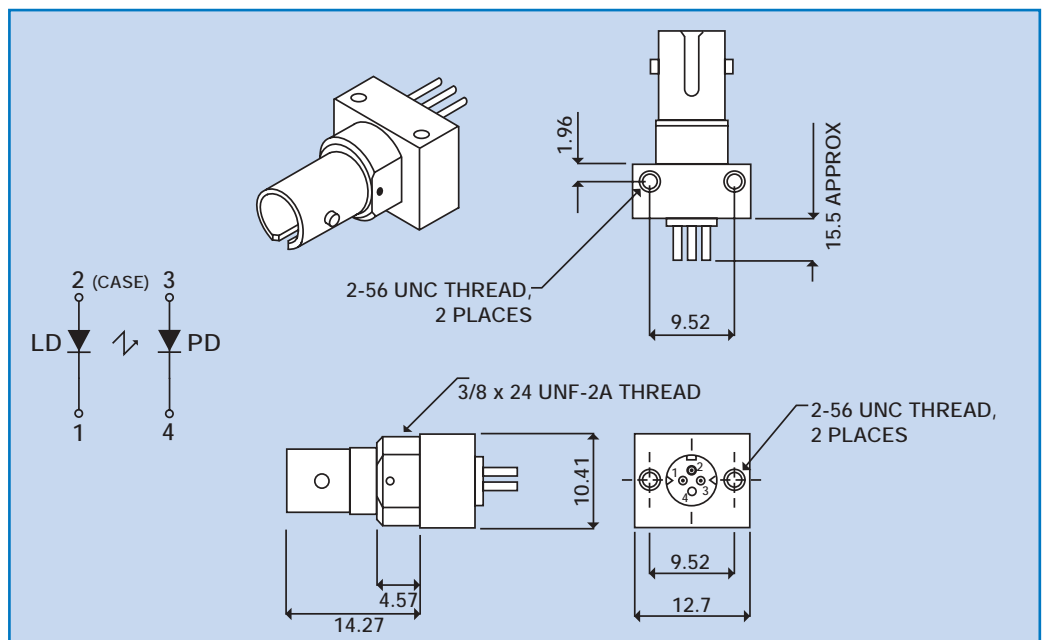

PHOTONIC
PRODUCTS

the **Laser Diode** specialists

300-0052-02 Specifications

Absolute Maximum Ratings (Tc = 25°C)

ITEM	SYMBOL	VALUE	UNIT
Fibre Output Power	P_f	0.8	mW
LD Reverse Voltage	V_{RLD}	2	V
PD Reverse Voltage	V_{RPD}	10	V
PD Forward Current	I_{FPD}	1.0	mA
Operating Temperature	T_{opr}	-40, +85	°C
Storage Temperature	T_{stg}	-40, +85	°C

Optical & Electrical Characteristics All optical data refer to a coupled 9/125µm fibre, (Tc = 25°C).

ITEM	SYMBOL	MIN.	TYP.	MAX.	UNIT	TESTING CONDITION
Fibre Output Power	P_f	0.3	0.5	0.8	mW	CW, I_{th} +25mA, kink free
Threshold Current	I_{th}	-	10	20	mA	CW
Peak Wavelength	λ	1520	1550	1580	nm	CW, $P_f=0.5mW$
Spectral Width	$\Delta\lambda$	-	2	5	nm	CW, $P_f=0.5mW$
Forward Voltage	V_F	-	1.2	1.6	V	CW, $P_f=0.5mW$
Rise/Fall Time	t_r/t_f	-	-	0.5	ns	$I_{bias}=I_{th}$, 10-90%
PD Monitor Current	I_m	100	-	-	µA	CW, $P_f=1.0mW$, $V_{RPD}=2V$
PD Dark Current	I_{DARK}	-	-	0.1	µA	$V_{RPD}=5V$
PD Capacitance	C_t	-	6	15	pF	$V_{RPD}=5V$, $f=1$ MHz

WARNING:

This laser device in operation produces visible and/or invisible laser radiation. Be sure to avoid direct exposure of human eyes to beams emitted from the laser diodes. Even though they are barely visible and/or invisible to the human eye, they can be extremely harmful. In particular, avoid looking directly into a laser diode or collimated beam along its optical axis when it is in operation. These devices are components to be used in producing a complete laser system. They do not emit radiation unless combined with other components by the end user.

NOTE: ESD precautions must be taken when handling this product.
Specifications subject to change without notice. E&OE

Laser Safety

The light emitted from these devices has been set in accordance with IEC60825. However, staring into the beam, whether directly or indirectly, must be avoided. IEC60825 classifies laser products into three different categories depending on light emitted, wavelength and eye safety.

CLASS II

"Caution", visible laser light less than 1.0mW. Considered eye safe, normal exposure to this type of beam will not cause permanent damage to the retina.

CLASS IIIA

"Danger", visible laser light between 1.0mW and 5.0mW. Considered eye safe with caution. Focusing of this light into the eye could cause some damage.

CLASS IIIB

"Danger", infrared (IR), and high power visible lasers considered dangerous to the retina if exposed.

NB: It is important to note that while complying with the above classifications, unless otherwise stated, our laser diode products are not certified and are designed solely for use in OEM products. The way in which the device is used in the final product may alter its original design classification, and it is the responsibility of the OEM to ensure compliance with the relevant standards.

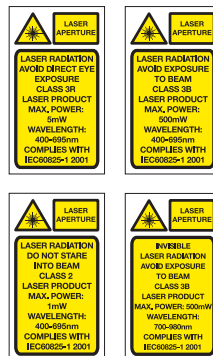

PHOTONIC PRODUCTS UK LIMITED

Pierce Williams, Sparrow Lane
Hatfield Broad Oak, Hertfordshire CM22 7BA, UK
Telephone: +44 (0) 1279 717170
Facsimile: +44 (0) 1279 717171
E-mail: sales@photonic-products.com
www.photonic-products.com

PHOTONIC PRODUCTS USA

Telephone: +1 714-841-1960
E-mail: salesusa@photonic-products.com

PHOTONIC PRODUCTS GERMANY

Telefon: +49 (0) 8142 / 669 8364
E-mail: salesgermany@photonic-products.com
www.photonic-products.com



PHOTONIC
PRODUCTS